

特性 Features

- 产品符合欧盟RoHS指令。
The product complies with the EU RoHS directive.
- 密封且安全，对安装位置不敏感。
Hermetically sealed and intrinsically safe. Not mounting position sensitive.
- 在恶劣环境下，产品触点不会被氧化或污染。
Operates in harsh environments without oxidation or contamination of contacts.
- 高压触点间填充有惰性气体。
High voltage isolation between open contacts, inert gas filled contact chamber.
- 产品设计与管控符合IATF-16949。
Product design and quality control in accordance to IATF-16949.
- 典型应用于车载电池、电机控制器、充电桩、光伏、储能。
Typical applications apply to Battery electric vehicles ,DC motor controller protection,DC charging pile, Photovoltaic controls,Energy Storage systems.



线圈参数 Coil Data

线圈电压 Coil Voltage	动作电压 Pickup Voltage	释放电压 Dropout Voltage	瞬间启动电流 Inrush Current	平均保持电流 Avg. Holding Current	保持功耗 Holding Power
12VDC	9VDC Max	1.2VDC Min	3.8A Max	0.5A Approx	6W Max
24VDC	18VDC Max	2.4VDC Min	2A Max	0.25A Approx	6W Max

备注：1、线圈参数值是环境温度为20℃下的理论值，因线圈电阻的影响以上参数约±10%的变动范围；2、线圈可靠的工作电压范围为85%~110%额定电压；3、如需其他额定电压，可特殊订货。
Remarks: 1. The coil parameter values are theoretical values at an ambient temperature of 20 °C, with a variation range of approximately ± 10% due to the influence of coil resistance; 2. The reliable working voltage range of the coil is 85%~110% of the rated voltage; 3. If other rated voltages are required, special orders can be made.

触点参数 Main Contact

触点形式 Contact Arrangement	1 Form A (SPST-NO)
触点极性 Contact Polarized	无极性 Nonpolarized
接触电阻(初始) Contact Resistance (Initial)	1mΩ (Typical Value)
负载电压 Load Voltage	12-1500VDC
额定电流 Current (continuous)	200A
机械寿命 Mechanical Life	2×10 ⁵ cycles
电气寿命 Electrical Life	图1 Graph 1
过载电流 Overload Current	图2 Graph 2

备注：1、阻性负载类别(L/R<0.1ms)；2、接通和分断转换频率，ON:OFF=1秒:9秒；3、测试环境温度为23±5℃；4、电气寿命是产品带载分断的次数。
Remarks: 1. Resistive load category (L/R<0.1ms); 2. Switching frequency between on and off, ON: OFF=1 sec: 9 sec; 3. The testing environment temperature is 23 ± 5 °C; 4. The electrical life is the number of times a product breaks under load.

性能参数 Performance Parameter

绝缘电阻 Insulation Resistance	1000MΩ@2500VDC (Initial) ≤50MΩ@1000VDC (End)
介质耐压 Dielectric Withstanding Voltage	AC3500V 1min ≤10mA
动作时间 Operate Time	30ms (Include bounce)
释放时间 Release Time	12ms (Include bounce)
弹跳时间 Bounce Time	5ms
冲击 Shock	20g peak, 1/2 sine(Operating)
正弦振动 Sine Vibration	20g peak, 80~2000Hz
湿度 Humidity	5%~85%RH
温度 Operating Temperature	-40℃~+85℃
重量 Weight	470g Approx

备注：1、线圈施加额定工作电压，无续流二极管；2、测试环境温度为20℃。
Remarks: 1. Apply rated working voltage to the coil without a freewheeling diode; 2. The testing environment temperature is 20 °C.

电气寿命参考曲线-图1 Electrical Life Reference Curve-Graph1

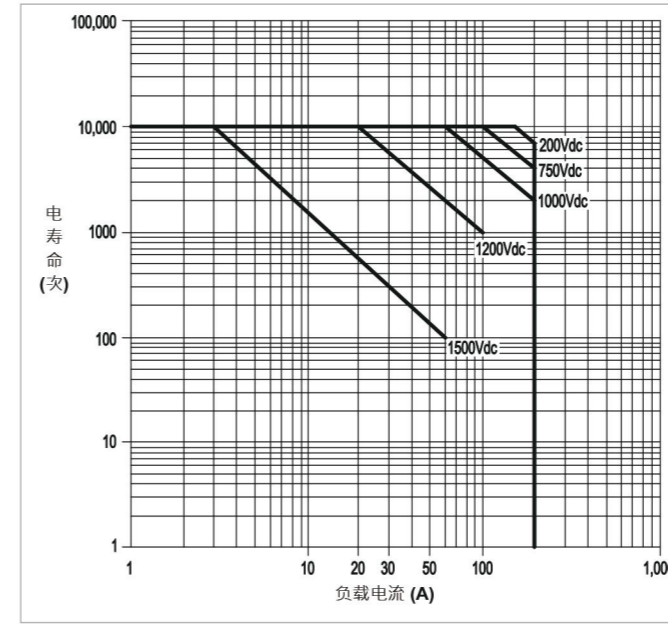

备注：1、以上数据曲线作为设计参考选型，不作为选型熔断器的依据；2、环境温度为23±5℃下。
Remarks: 1. The above data curve is used as a design reference for selection and not as a basis for selecting fuses; 2. At an ambient temperature of 23 ± 5 °C.

过载电流参考曲线-图2 Overload Current vs Time Reference Curve-Graph2

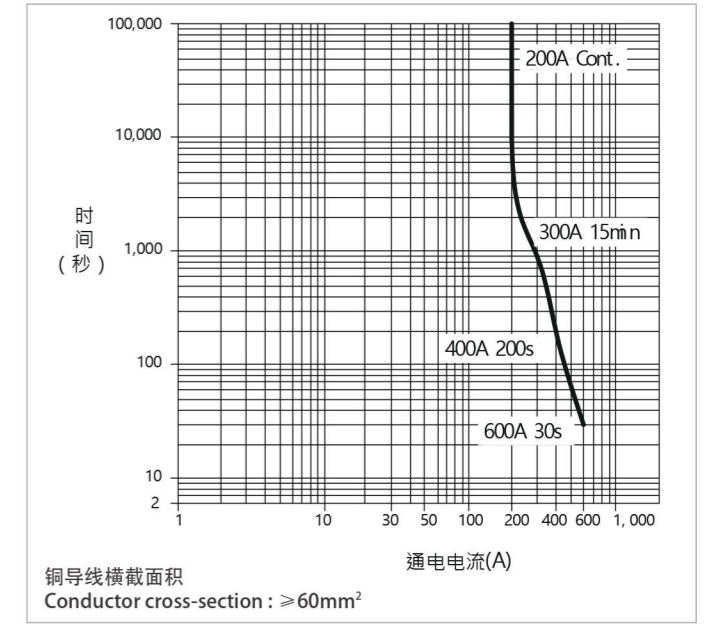

尺寸图&接线原理图 Dimension & Wiring

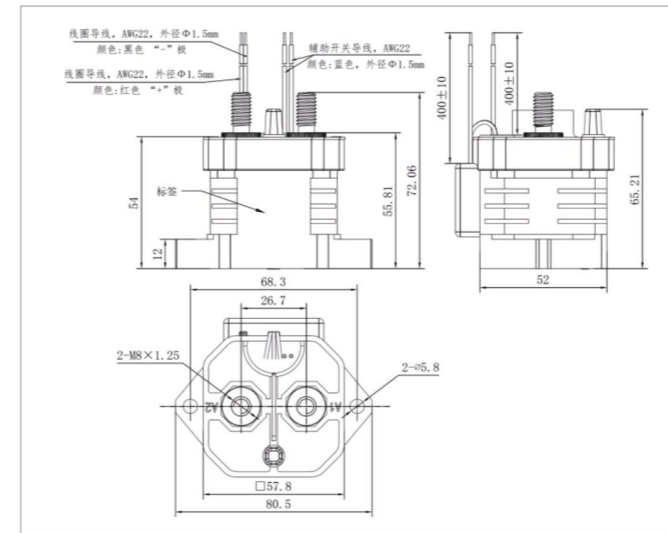

安装紧固件 Fastener	扭力范围 Torque Range	
	主触头接线 Main contacts wiring	底部固定 Product mount
M8 (配套提供 Provided)	9~12N·m	1.8~3.5N·m

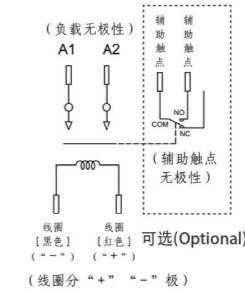

备注：
1、尺寸单位：mm，视角：；
2、未注尺寸公差：
标称值<10mm为±0.3，
标称值10~50mm为±0.6，
标称值>50mm为±1.0；

Remarks:
1.Dimension unit: mm, viewing angle: ;
2. Undeclared dimensional tolerance:
± 0.3 for nominal values<10mm,
The nominal value of 10-50mm is ± 0.6, ±1.0 for
nominal values greater than 50mm;

订货说明 Ordering Information

EVQ200 E 12 D A 5***

额定电流 Rated Current: "200" = 200A

线圈电压 Coil Voltage: "12" = 12VDC "24" = 24VDC

安装方式 Mounting: "A" = 立式安装 Bottom mount

产品代码 Product code

触点形式 Main contacts feature:
"E" = 主触头为一组常开，触头不分极性；1 form A(ON), non-polarized;
"G" = 主触头为一组常开，触头不分极性，带一组常开辅助触点；
1 form A(ON) add AUX contacts(ON), non-polarized;

线圈引出方式 Coil lead out:
"D" = 导线式，不带连接器；Wire Without Connectors
"E" = 导线式，带连接器；Wire With Connectors
(制造商推荐Manufacturer's recommendation)